

# Les altes freqüències a la indústria alimentària

**Marc PERMANYER**

Cap de projecte tècnic

CENTA – Centre de Noves Tecnologies i Processos Alimentaris

[marc@centa.cat](mailto:marc@centa.cat)

## Definicions

S'entén per **RADIOFREQUÈNCIES** a les ones electromagnètiques que cobreixen una freqüència de 30 kHz a 400 MHz. És a dir una energia entre  $1.2 \cdot 10^{-10}$  eV i  $1.7 \cdot 10^{-6}$  eV.

S'entén per **MICROONES** a les ones electromagnètiques que cobreixen una freqüència de 300 MHz a quasi 30 GHz. És a dir una energia entre  $1,2 \cdot 10^{-6}$  eV i  $1,2 \cdot 10^{-2}$  eV.

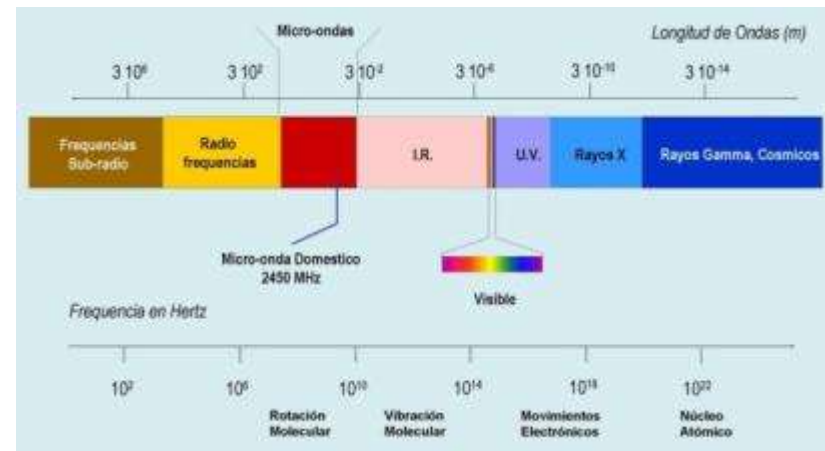

**Nota: el visible té una energia entre 1.8 eV i 3.1 eV**

# Aplicacions de les Altes Freqüències

# Aplicacions de les Altes Freqüències

## Túnel de microones: Sistema continu

Armari elèctric



Caldera



Refrigeració

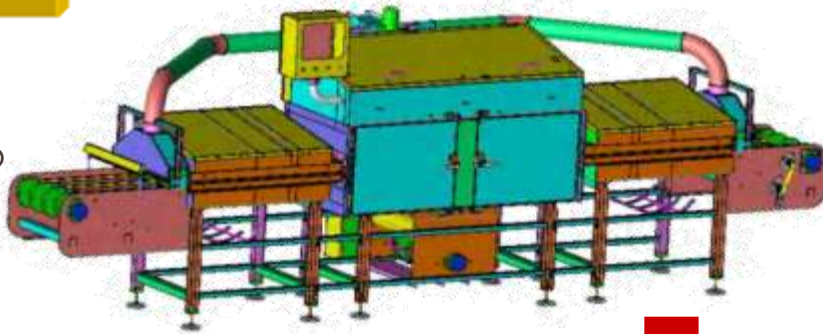

**TECNIO**

Be tech. Be competitive



CENTRE DE NOVES TECNOLOGIES  
I PROCESSOS ALIMENTARIS

**IRTA**  
RECERCA I TECNOLOGIA  
AGROALIMENTARIES

# Aplicacions de les Altes Freqüències

## Equips de radiofreqüències: Sistema continu (convencional)

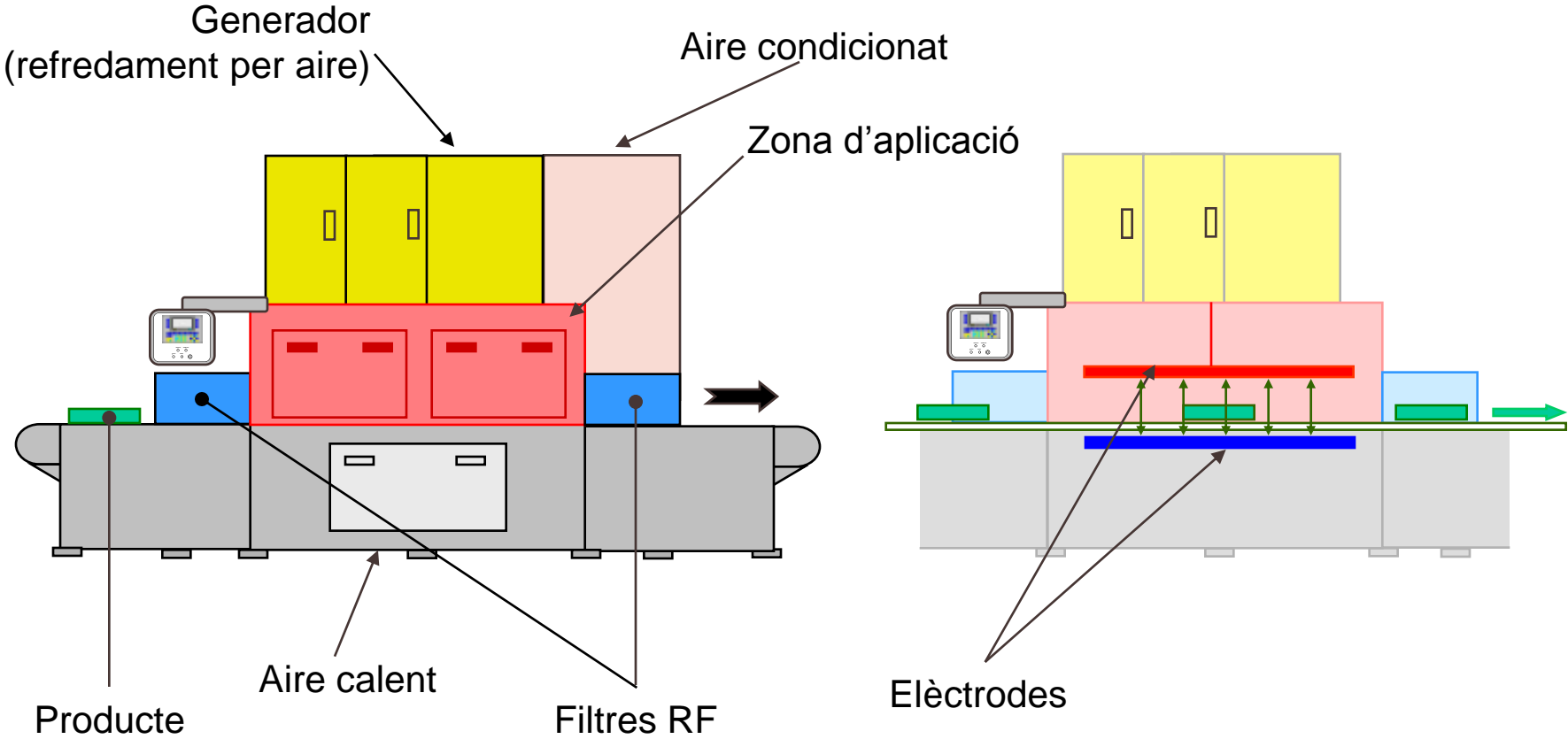

## Aplicacions de les Altes Freqüències

### Equips de radiofreqüències: Sistema continu (convencional)



**TECNIO**

Be tech. Be competitive



CENTRE DE NOVES TECNOLOGIES  
I PROCESSOS ALIMENTARIS

**IRTA**  
RECERCA | TECNOLOGIA  
AGROALIMENTARIES

## Aplicacions de les Altes Freqüències

### Principals aplicacions industrials RF i MO



- a) Escalfament de productes alimentaris (1)
- b) Pasteurització d'aliments (2)
- c) Assecat de productes, *post-baking* (3)
- d) Postcollita: desinfecció de fruites senceres (4)
- e) Descongelació de matèries primes (5)
- f) Altres

## Principals aplicacions industrials RF i MO

### Blanquejat de vegetals (2450 MHz)

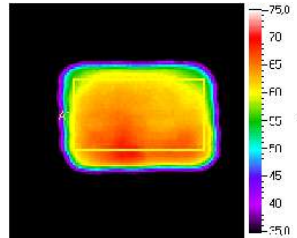

## Pasteurització d'aliments en l'envàs definitiu

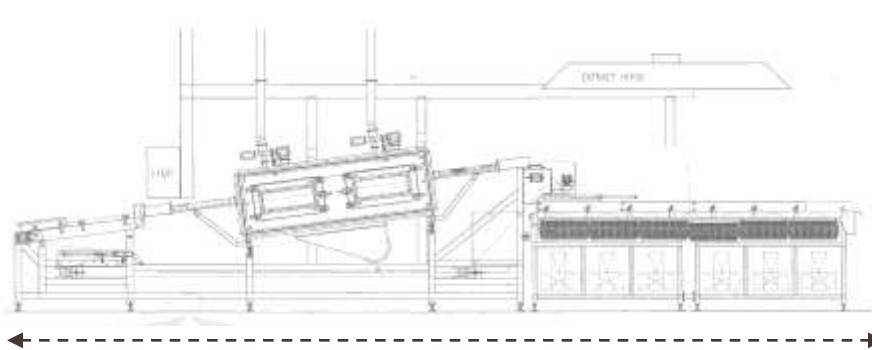

25 m



## Pasteurització de plats preparats

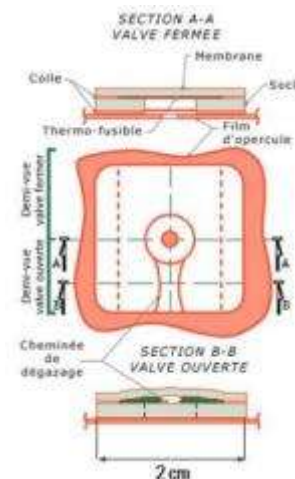
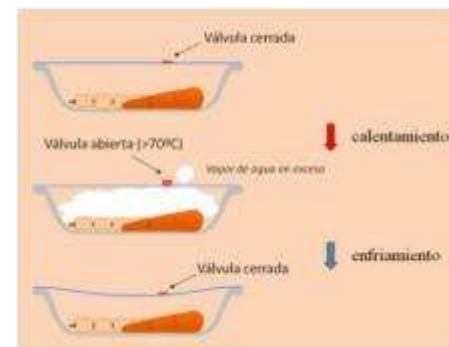

Cortesia de Nutripack, 2005

# Aplicacions de les Altes Freqüències

## Pasteurització (vegetals): Comparació microones vs autoclau

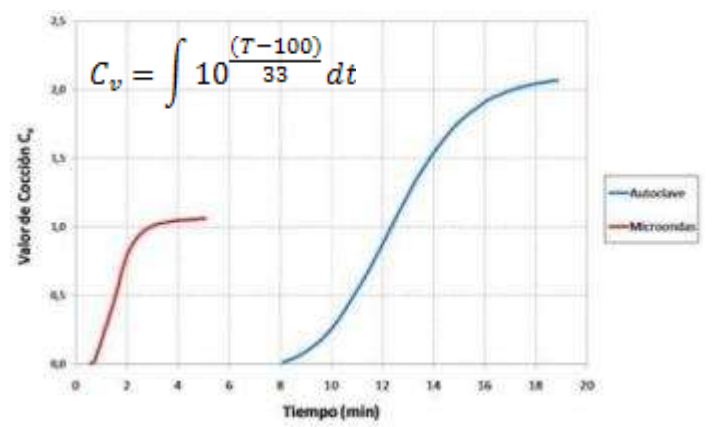
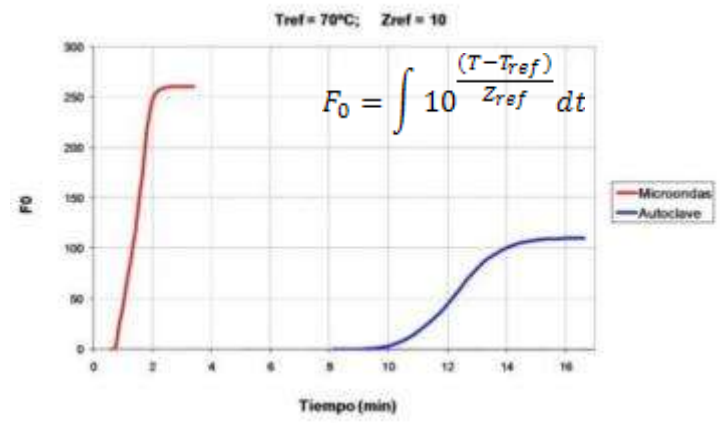
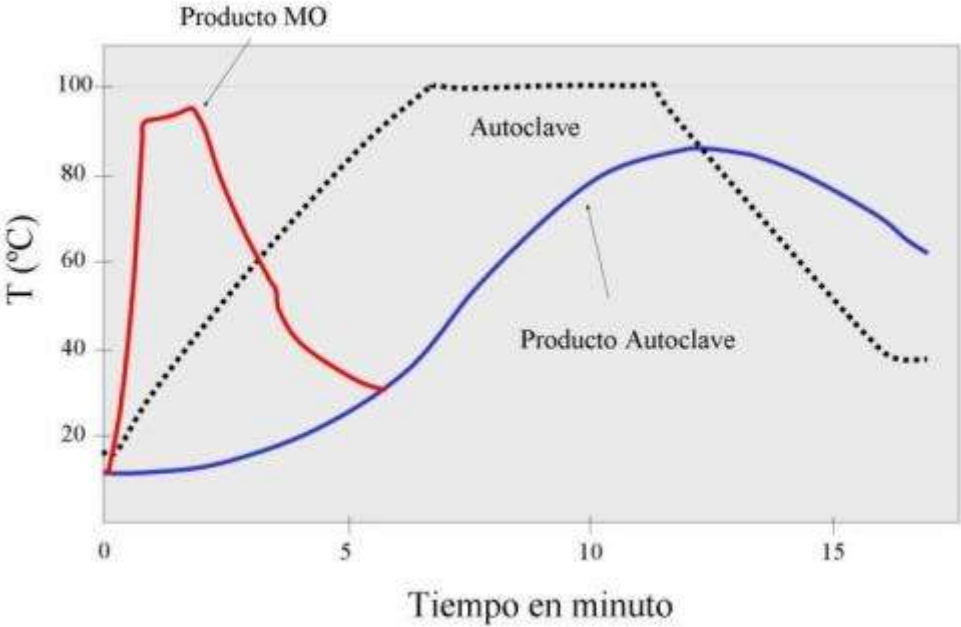

# Principals aplicacions industrials RF i MO

## Post-baking de productes de pa i pastisseria per RF

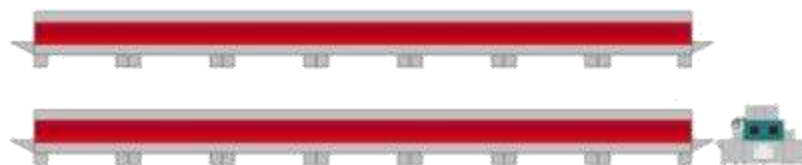
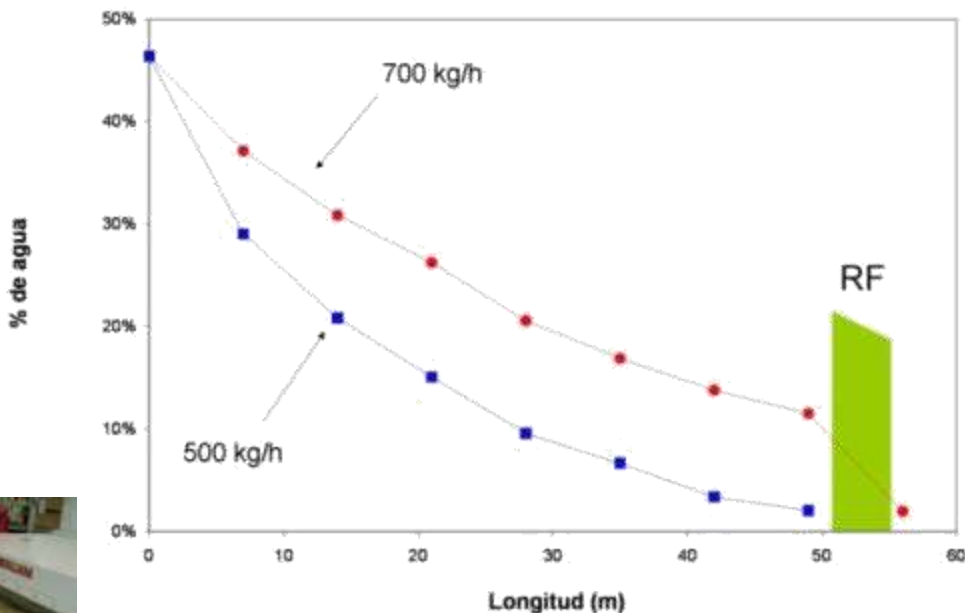

## Postcollita, desinfecció de fruites senceres

Taronja tractada per RF (Birla et al 2004)

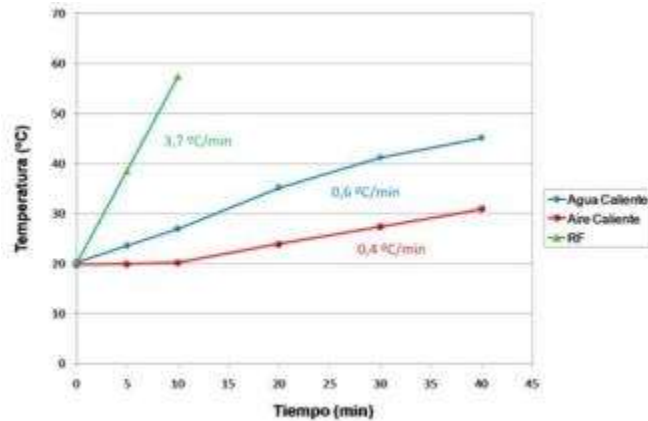

Préssec tractat per RF (ISAFRUIT Project)

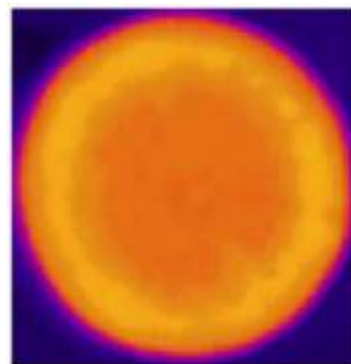

Tractada per RF (5 min)

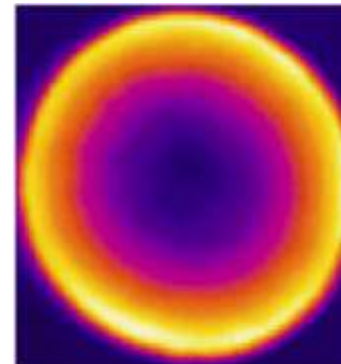

Tractada per aire calent (10 min)



## Principals aplicacions industrials RF i MO

### Descongelació de blocs de carn / peix per RF

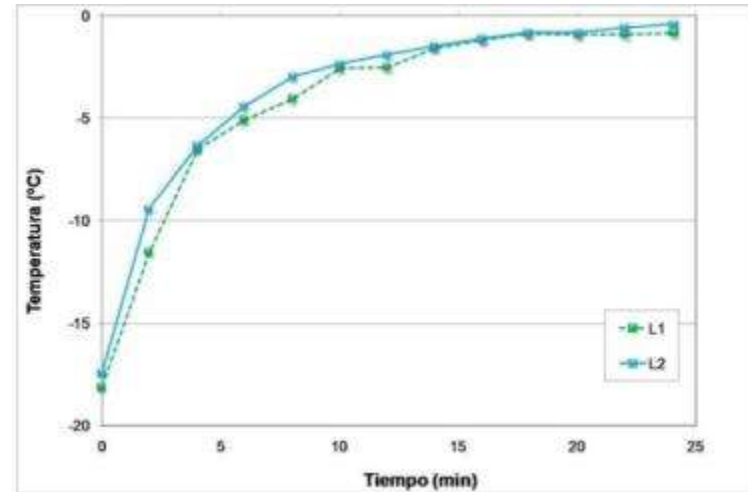

**TECNIO**

Be tech. Be competitive



CENTRE DE NOVES TECNOLOGIES  
I PROCESSOS ALIMENTARIS

**IRTA**

RECERCA I TECNOLOGIA  
AGROALIMENTARIES

## Descongelació de blocs de carn / peix per RF

Descongelació de blocs de carn de porc de 20-25 kg

Tractament RF → 18-24 minuts per arribar a  $-1.0/-2.0^{\circ}\text{C}$

Tractament convencional per aire → 140 minuts per arribar a  $-3.5^{\circ}\text{C}$

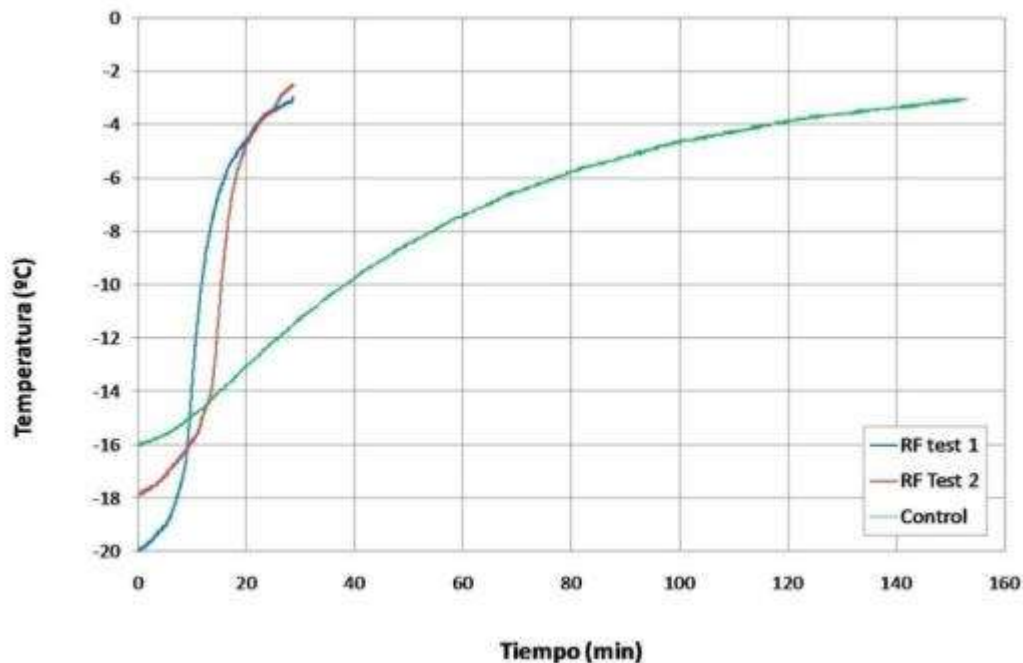

# AVANTATGES I RESTRICCIONS DE LES ALTES FREQUÈNCIES (RF/MO)



Millor eficiència energètica

Menor generació de residus

Generació interna de calor: millor qualitat sensorial

Permeten processar en continu

RF té major poder de penetració que MO

Disseny de procés és específic de:

- Producte
- Composició
- Format

Cal validació de cada canvi d'aquests



# MOLTES GRÀCIES PER LA VOSTRA ATENCIÓ

**Marc PERMANYER**

Cap de projecte tècnic

**CENTA – Centre de Noves Tecnologies i Processos Alimentaris**

[marc@centa.cat](mailto:marc@centa.cat)

<http://www.centa.cat>

**TECNIO**

Be tech. Be competitive



CENTRE DE NOVES TECNOLOGIES  
I PROCESSOS ALIMENTARIS

**IRTA**

RECERCA | I | TECNOLOGIA  
AGROALIMENTARIES